

# WORLD MARKET®

## Assembly Instructions

### San Marino Slope Arm Chair

SKU-619716

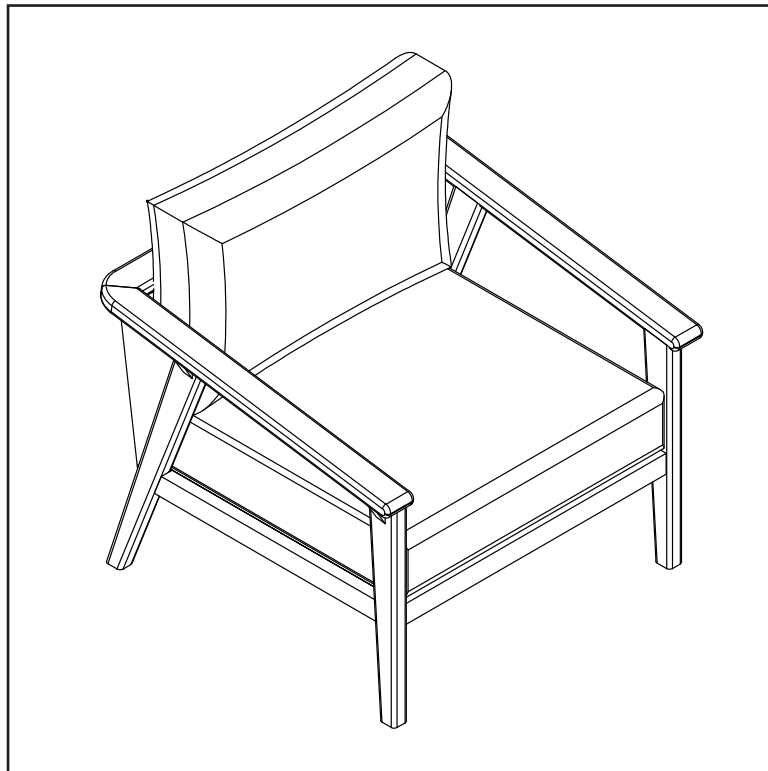



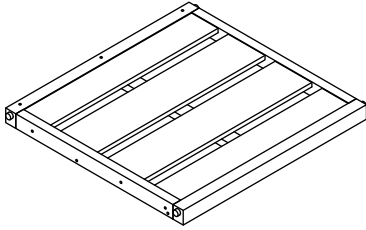
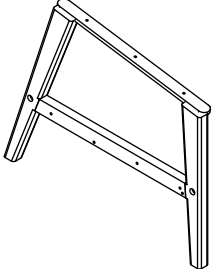
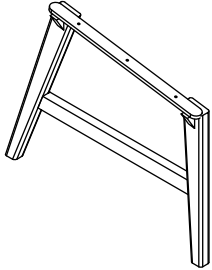
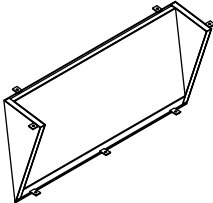
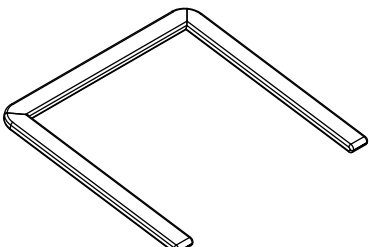
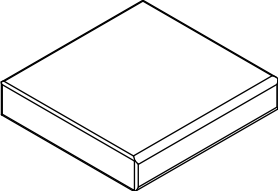
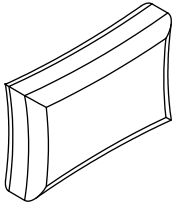

THANK YOU FOR PURCHASE. IF YOU HAVE ANY QUESTIONS  
PERTAINING TO THE ASSEMBLY OF THIS FURNITURE PIECE, PLEASE CONTACT  
THE NEAREST WORLD MARKET STORE.  
IF YOU ARE NOT NEAR A STORE, PLEASE CALL OUR CUSTOMER SERVICE CALL  
CENTER TOLL FREE AT 877-967-5362 FOR ASSISTANCE.

All products sold at World Market are not for commercial use and are  
intended for residential use only.

# Component List

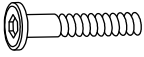
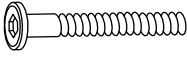
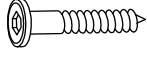
LABEL	PICTURE	DESCRIPTION	QTY
A		Seat Frame	1
B		Right Leg Frame	1
C		Left Leg Frame	1
D		Backrest Weave Frame	1
E		Armrest Frame	1
F		Seat Cushion	1
G		Back Cushion	1

# Hardware List

LABEL	PICTURE	DESCRIPTION	QTY
H-1		Short Allen Bolt M6 x 30mm	6
H-2		Long Allen Bolt M6 x 45mm	10
H-3		Allen Screw M6 x 30mm	7
H-4		Flat Washer M6 x 16mm	13
H-5		Spring Washer M6 x 1.5mm	13
H-6		Allen Key	1

# Assembly Preparation

## Before Beginning:

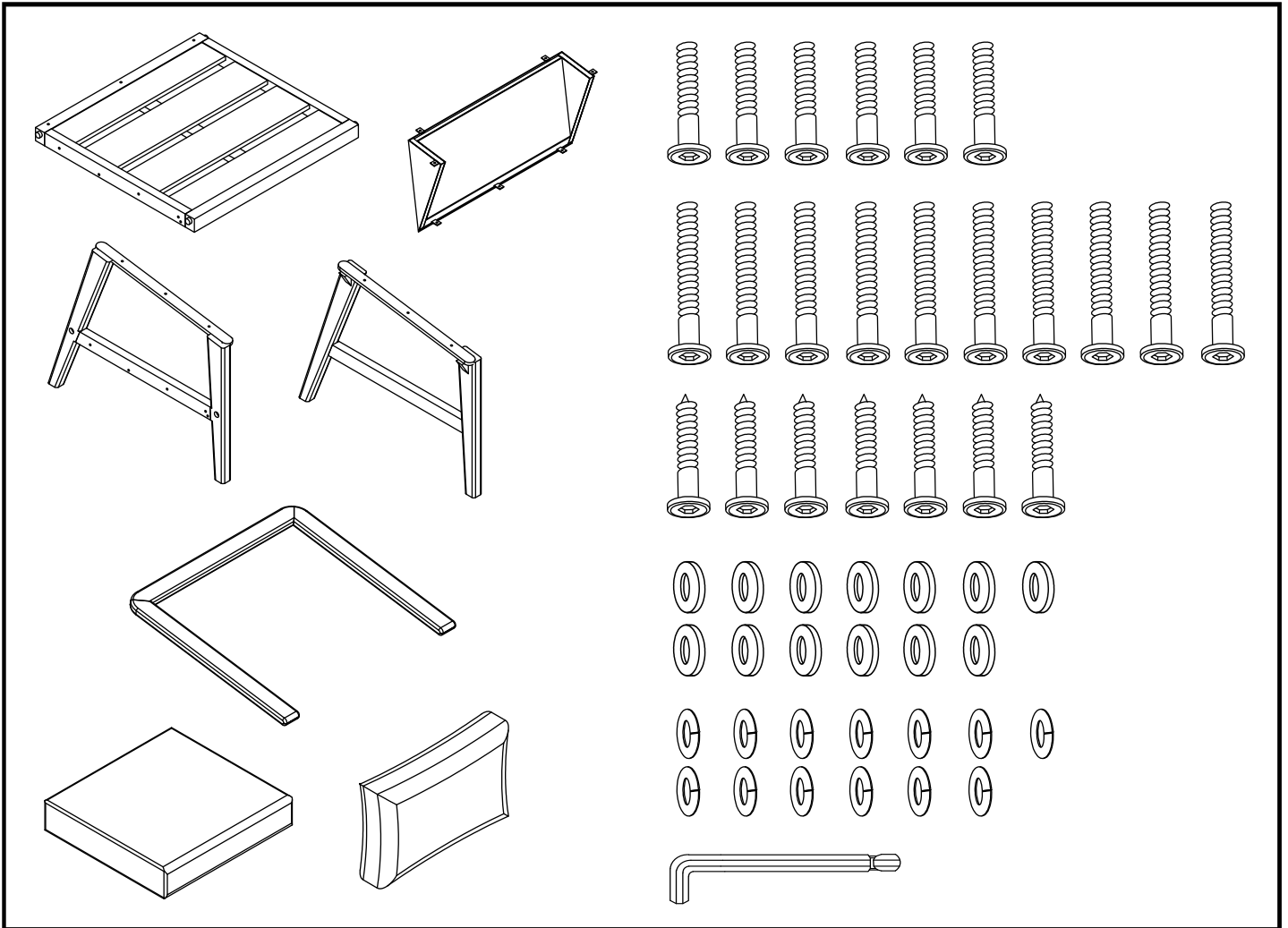

- **Unpack all hardware bags and components to ensure you have all parts.**



- **Read instructions, cover to cover.**



- **Have 2 adults on hand for assembly.**



- **Do not assemble on flooring or carpet.**



- **Assemble on a clean non-marring surface (packing foam).**



- **Save all packaging until finished.**



- **In case of missing parts, please contact your nearest World Market store or call our customer service call center at call 1-877-967-5362.**

# Assembly Steps

**NOTE:** It is strongly recommended that two adults are on hand for the assembly of this product.

## Step 1

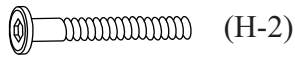

(H-2)

Long Allen Bolt (M6 x 45mm) x 5



(H-6)

Allen Key x 1

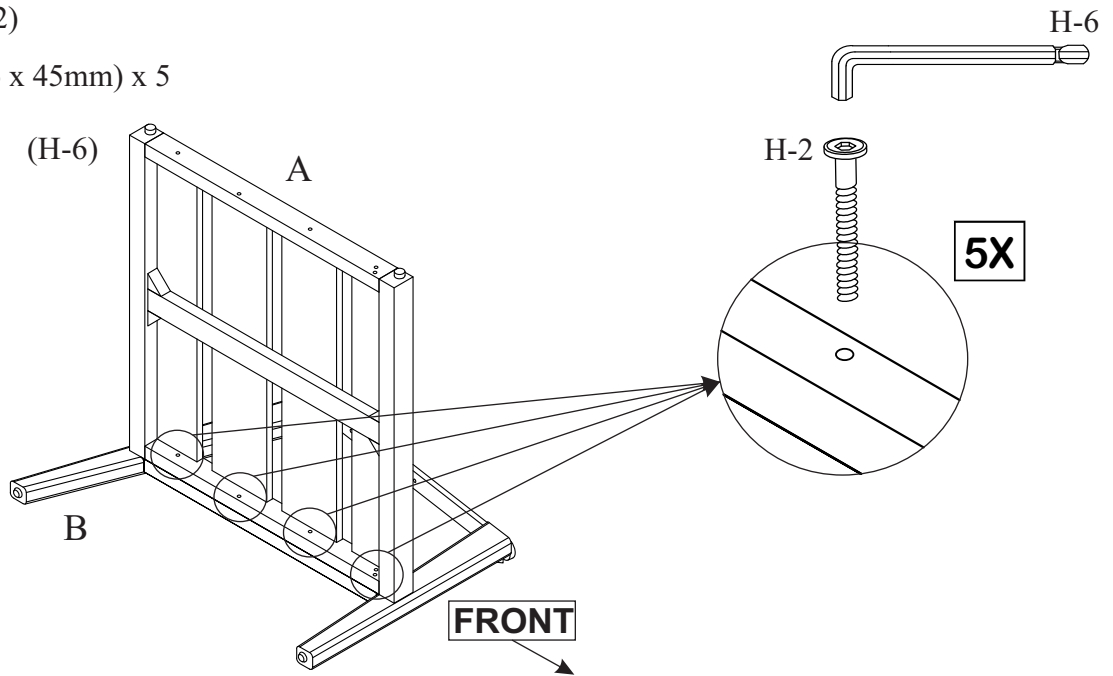

Using a second person to assist you, place Right Leg Frame (B) on its side on a padded, non-marring surface. Align wooden tenons and the 2 mounting holes on Seat Frame (C) with the corresponding pre-threaded holes on Right Leg Frame (B) as shown. Secure Seat Frame (A) to Right Leg Frame (B) using Long Allen Bolts (H-2). Engage bolts **but do not fully tighten** them using Allen Key (H-6).

## Step 2

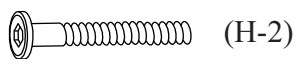

(H-2)

Long Allen Bolt (M6 x 45mm) x 5

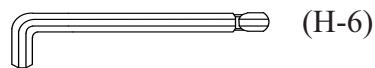

(H-6)

Allen Key x 1

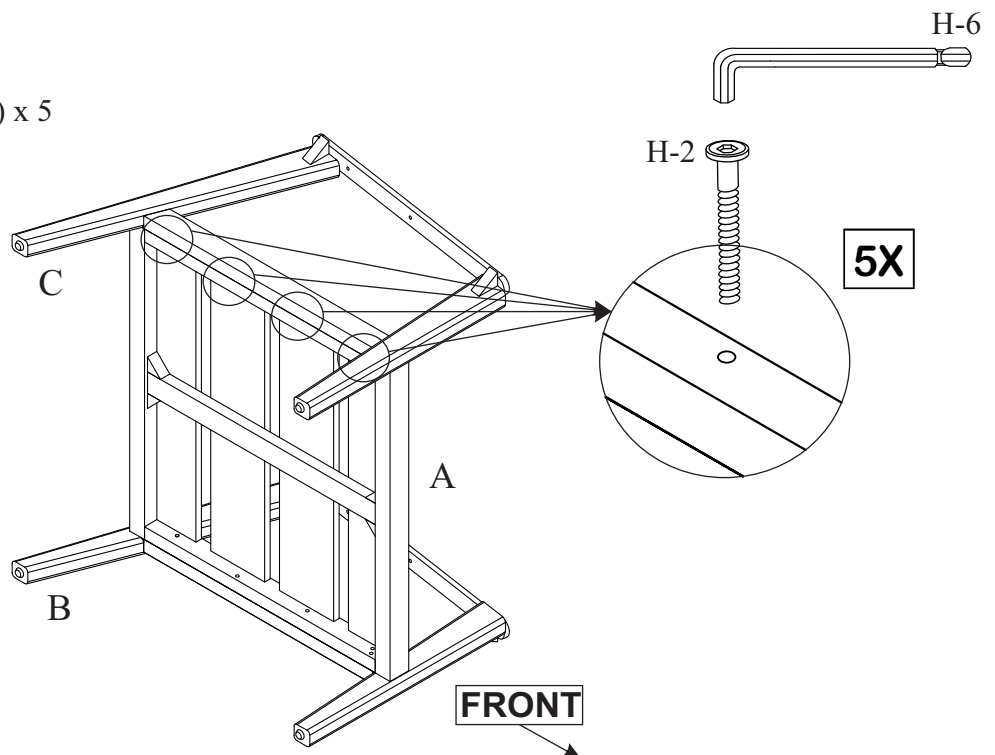

Align wooden tenons and the 2 mounting holes on Seat Frame (A) with the corresponding pre-threaded holes on Left Leg Frame (C) as shown. Secure Seat Frame (A) to Left Leg Frame (C) using Long Allen Bolts (H-2). Engage bolts **but do not fully tighten** them using Allen Key (H-6).

# Assembly Steps

## Step 3

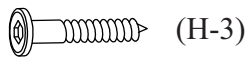

Allen Screw (M6 x 30mm) x 3

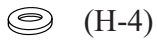

Flat Washer (M6 x 16mm) x 3

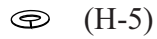

Spring Washer (M6 x 1.5mm) x 3



Allen Key x 1

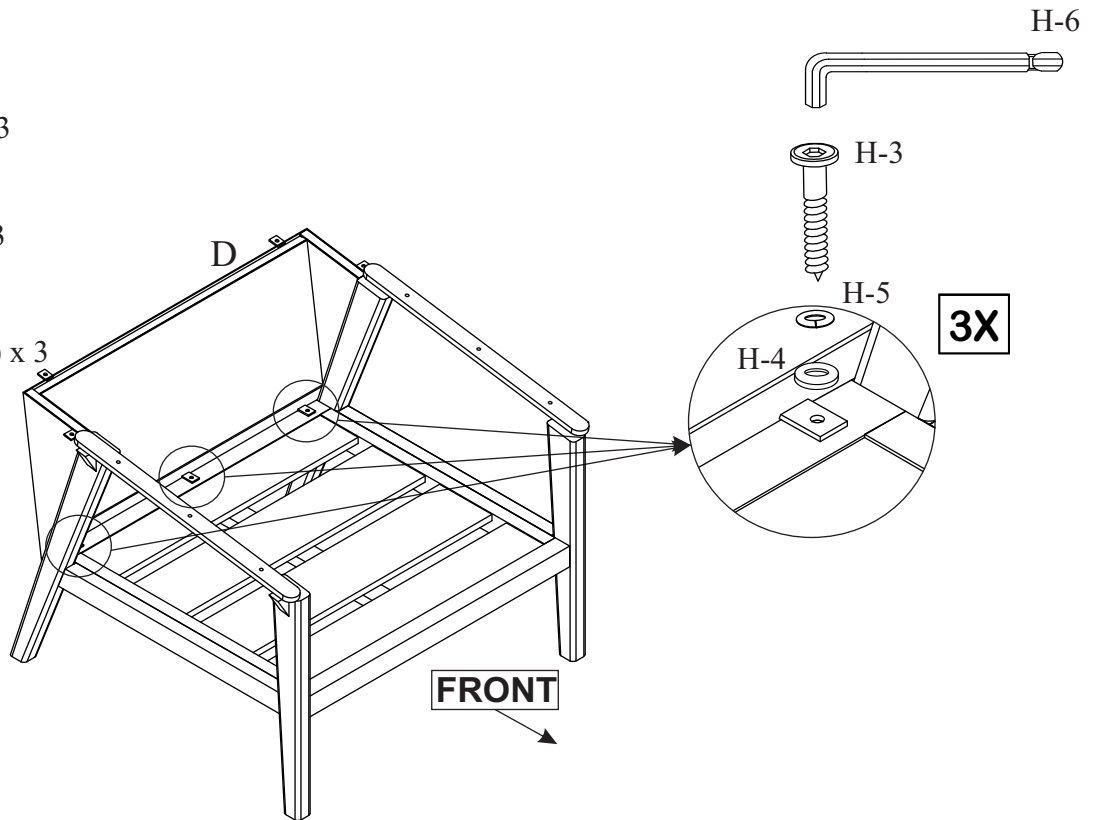

Flip assembly onto legs. Align Backrest Weave Frame (D) with the Seat Frame (A) as shown. Secure Backrest Weave Frame (D) to Seat Frame (A) using Allen Screws (H-3), Flat Washers (H-4) and Spring Washers (H-5), stacking the hardware in the order as shown. Engage screws **but do not fully tighten** them using Allen Key (H-6).

## Step 4



Short Allen Bolt (M6 x 30mm) x 6

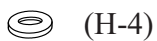

Flat Washer (M6 x 16mm) x 6

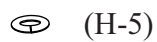

Spring Washer (M6 x 1.5mm) x 6

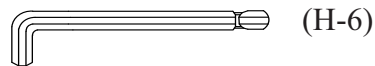

Allen Key x 1

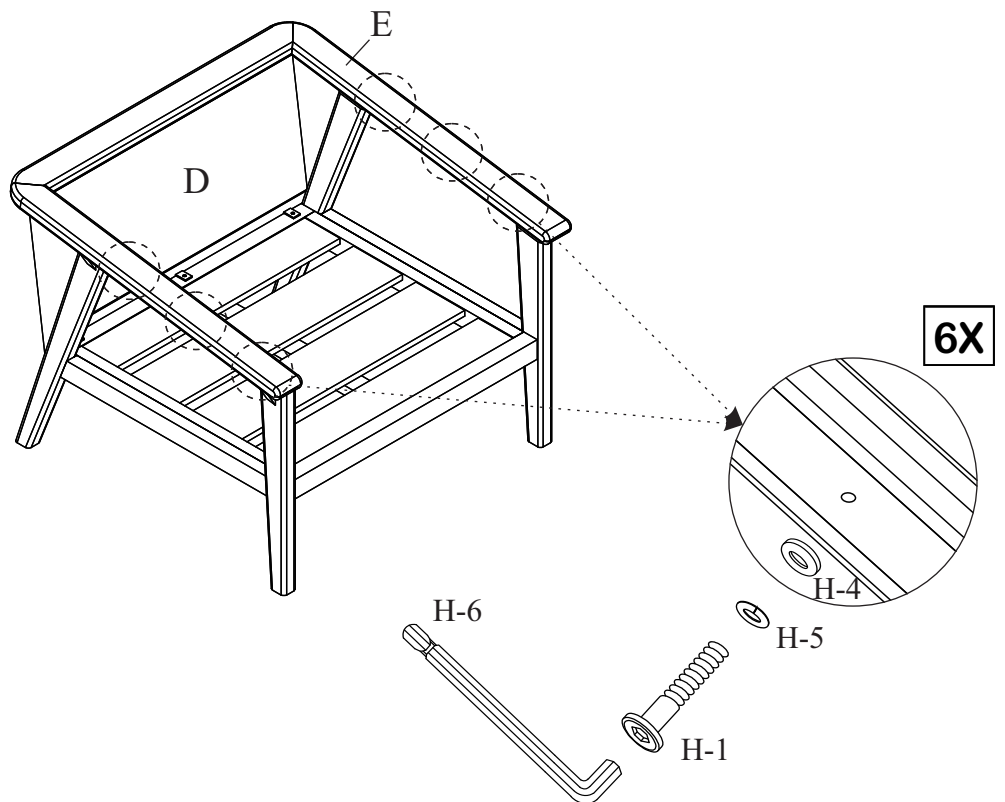

Align Armrest Frame (E) to Right Leg Frame (B) and Left Leg Frame (C) as shown. Secure Armrest Frame (E) to Right Leg Frame (B) and Left Leg Frame (C) using Short Allen Bolts (H-1) and Flat Washers (H-4) and Spring Washers (H-5), stacking the hardware in the order as shown. Engage bolts **but do not fully tighten** them using Allen Key (H-6).

# Assembly Steps

## Step 5

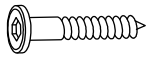

(H-3)

Allen Screw (M6 x 30mm) x 4

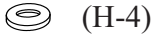

(H-4)

Flat Washer (M6 x 16mm) x 4

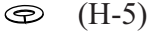

(H-5)

Spring Washer (M6 x 1.5mm) x 4



(H-6)

Allen Key x 1

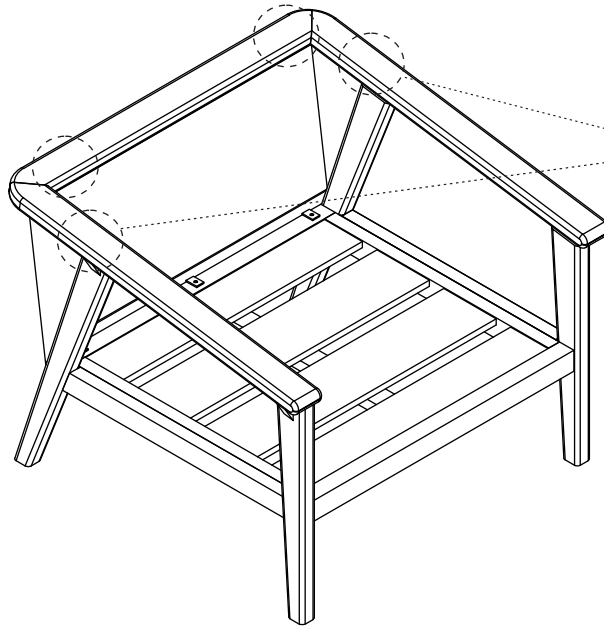

4X

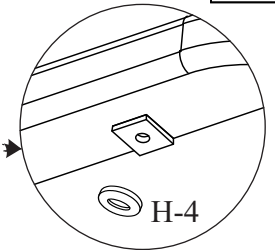

H-5



H-3

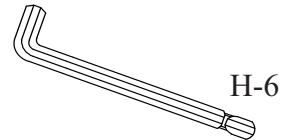

H-6

Align the Backrest Weave Frame (D) to the Armrest Frame (E) as shown. Secure Backrest Weave Frame (D) to Armrest Frame (A) using Allen Screws (H-3), Flat Washers (H-4) and Spring Washers (H-5), stacking the hardware in the order as shown. Engage all screws first, then **FULLY TIGHTEN all Bolts (H-1), (H-2) and Screws (H-3) from this and previous steps with Allen Key (H-6).**

## Step 6

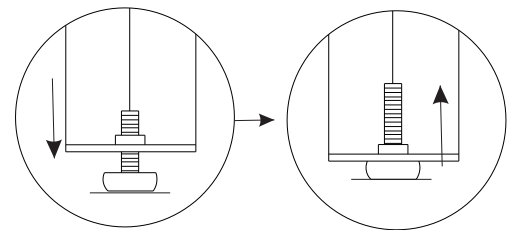
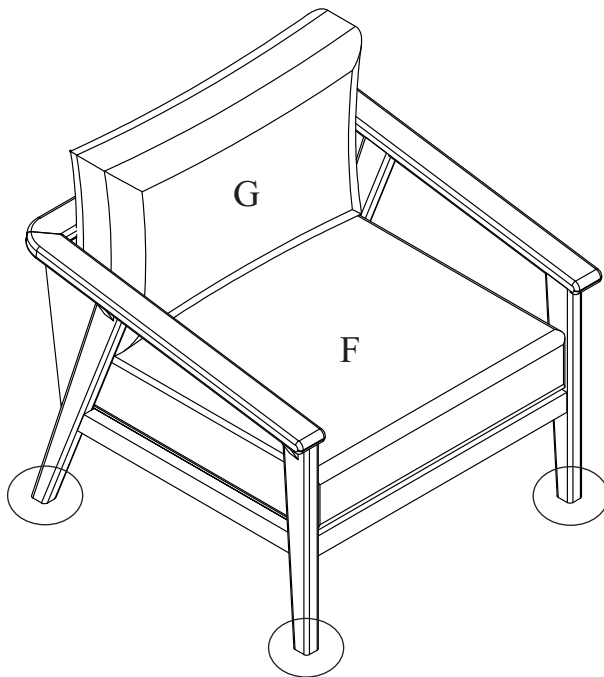

**NOTE:** Levelers can be used for additional adjustment if needed.

Place Seat Cushion (F) onto Seat Frame assembly as shown, making sure the cushion sits flush along the back of the frame assembly. Next, place Pillow (G) against the back assembly. Using a second person to assist you, place the completed assembly into the desired location and then finalize any leveling adjustments using the adjustable levelers as shown. Assembly is now complete and the product is ready for use.

**CAUTION:** Adjust pre-installed levelers only **AFTER** the unit has been moved into the desired location for use. **DO NOT** drag the unit as this may damage the levelers.

# Care & Maintenance



- Do not put hot items directly on furniture surface.



- Do not clean furniture with harsh cleansers or polish.



- Do not place furniture near heating or cooling vents.



- Do not write on furniture without a padded barrier to protect the surface.



- Store furniture or use an appropriate furniture cover during cold or inclement weather.



- All products sold at World Market are not for commercial use and are intended for residential use only.



- Dust and pick-up spills using a clean, non-colored, lint-free cloth.



- Stains may be removed with mild soap solution and damp cloth.

**CAUTION:** As with any wood, the color may fade if left in direct sunlight or inclement weather. Minor cracking may occur with age. These are naturally occurring features of wood and do not affect product performance.

We recommend using our Outdoor Wood Furniture Finish sold separately to help preserve and protect the wood and finish.



# **WORLD MARKET** LIMITED ONE-YEAR WARRANTY – Outdoor Furniture

For your customer satisfaction, this product carries a LIMITED ONE-YEAR WARRANTY from the date of purchase. This limited warranty only applies to World Market brand furniture, and not to other furniture brands sold on World Market's website.

Where applicable, the limited warranty provides coverage for:

1. **Manufacturing, Material and Workmanship Defects:** Includes defects related to core frame/structure substrates (wood, metal and stone/tile); complete breakage of hardwood; cracking, splitting or lifting of wood veneer or laminated top surfaces caused by process failure; broken welds or improperly coated metal frame components (powder coating or painted); outdoor fabric, nautical rope and woven Textlene® defects including tears, misprints, fraying, crease marks, skip stitches or open seams; synthetic resin wicker breakage or unraveling; and other component failures that are a direct result of manufacturing or workmanship defects.
2. **Cushions:** Loss of resiliency from a material breakdown of foam or fiber filling, which should not be confused with softening or sagging during normal use.
3. **Outdoor Furniture Components (Hardware & Mechanisms):** Includes defects to pre-installed components or hardware provided to the customer for assembly such as metal bases, swivel plate mechanisms; for umbrellas, canopy crank mechanism, spring loaded pole pins (for adjusting height); and other components such as bent or stripped threaded leg posts and adjustable levelers. Coverage also includes protection against rust and corrosion on hardware. For missing, damaged, corroded, or misplaced hardware components such as bolts or washers, please contact Customer Service at: 877-967-5362.

## **This LIMITED ONE-YEAR WARRANTY does NOT cover:**

1. Damage due to mishandling during transportation from store or transportation without original protective packaging.
2. Abuse, negligence (product misuse), improper storage, stacking or wear and tear that may result in or from:
  - a. **Wood & Veneer:** Mishandling, prolonged exposure to moisture, peeling or discoloration caused by exposure to moisture or excessive sunlight, heat; splintered, dented or nicked panels, legs or component edges or paint/finish blemishes; or treatment with corrosive chemicals (dyes, inks, paints or harsh cleaning products). **NOTE: As with any outdoor rated wood, the color may fade if left in direct sunlight of inclement weather. Minor cracking may occur with age. These are naturally occurring features of wood and do not affect product performance.**
  - b. **Fabric (Including Sunbrella® Fabrics), Rope, Textlene®, All-Weather Wicker:** cuts, punctures, tears, burns, pet damage, or treatment with corrosive chemicals (dyes, inks, paints or harsh cleaning products), exposure to fire, high heat, water, or prolonged exposure to direct sunlight that may cause splitting, peeling, fraying or discoloration with time.
  - c. **Foam (Cushions):** Flattening, relaxing or softening of foam components that comes with normal use.
  - d. **Hardware Components:** improper installation or misuse/substitution of hardware components not defined in the Assembly Instructions for the product (if applicable)
3. Damage due to prolonged environmental/inclement weather exposure such as direct sunlight, extreme heat, water or extreme humidity, strong winds, any bright light source (natural or artificial), chlorine or saltwater pools, or any environment that the product is not intended for. We HIGHLY recommend storing furniture, umbrellas and cushions with outdoor rated furniture covers and out of direct exposure during the winter or inclement weather events.
4. This warranty is applicable for outdoor furniture products purchased for residential use only

For additional information on returns, please visit: <https://www.worldmarket.com/category/customer-service/returns.do>

**All products sold at World Market are NOT FOR COMMERCIAL USE and are intended for residential use only. Products purchased for commercial use will VOID all warranty provisions as listed above.**

Any claims under this LIMITED ONE-YEAR WARRANTY are valid and applicable only as to the original purchaser and must be accompanied by proof of purchase. Warranty claims should be submitted to a World Market store or through World Market Customer Service Call Center, Toll Free at 877-967-5362.

For valid warranty claims, World Market will repair or replace the product, or offer a full or partial credit, in the sole discretion of World Market. This LIMITED ONE-YEAR WARRANTY gives you specific legal rights and you may also have other rights which vary from state to state.

(OUTDOOR FURNITURE 1LW\_v1.3\_051122)